

LANCASTER

LAN2520: 10A, 10G, 10H, K5

LAN2620: K1, K3, K7, K9

LAN2720: 10F, 10E, 10M, 10N, 10K, 10J

100 min.

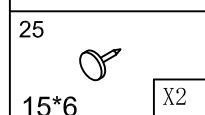
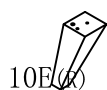
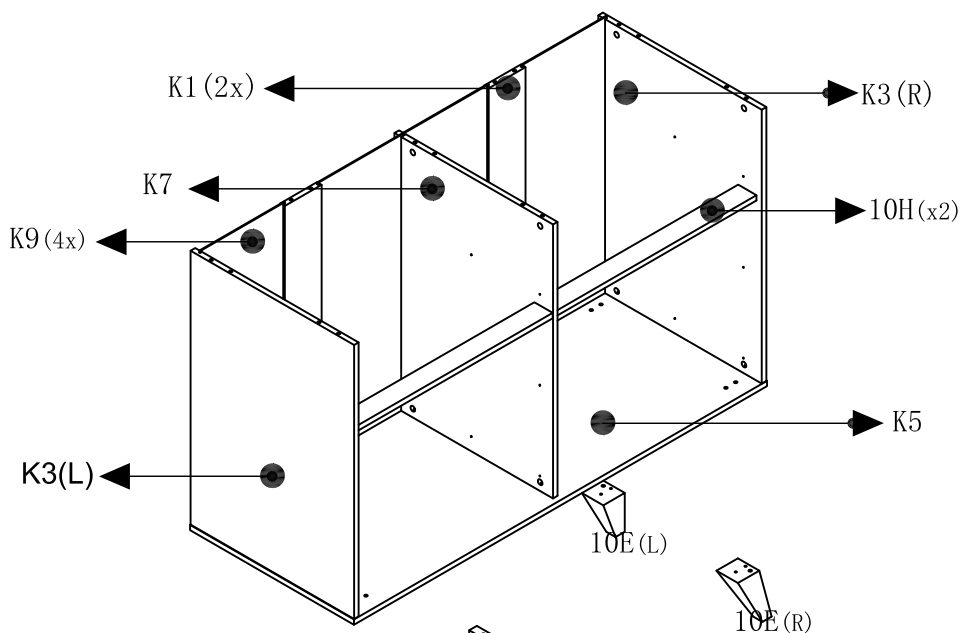
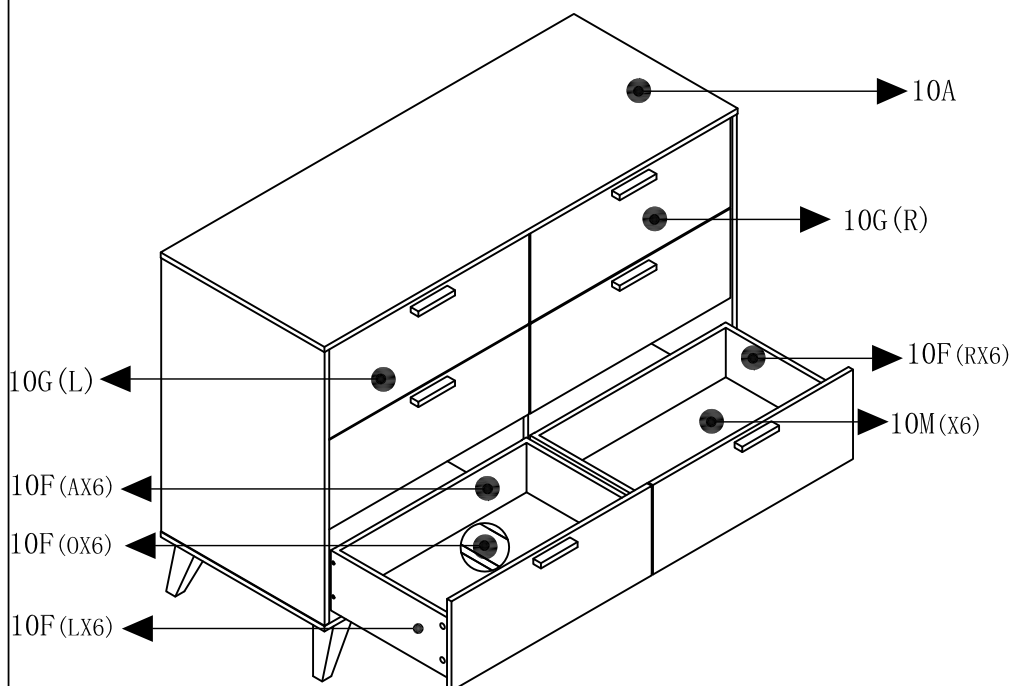

10K

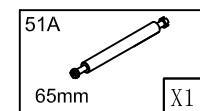
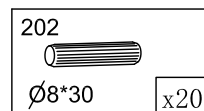
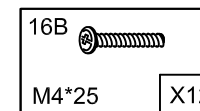
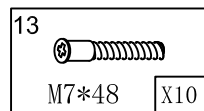
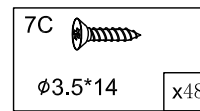
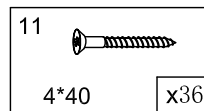
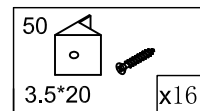
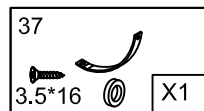
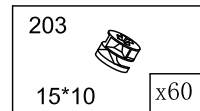
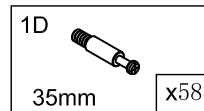

10J

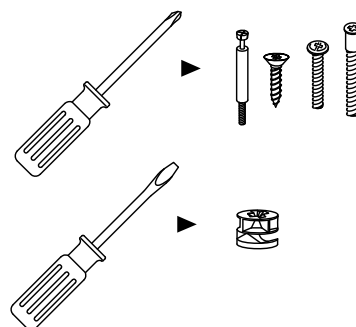
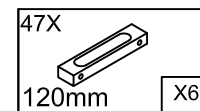
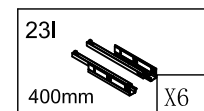

202 Ø8*30 X14	13 M7*48 X10	51A 65mm X1
1D 35mm X8	203 15*10 x10	

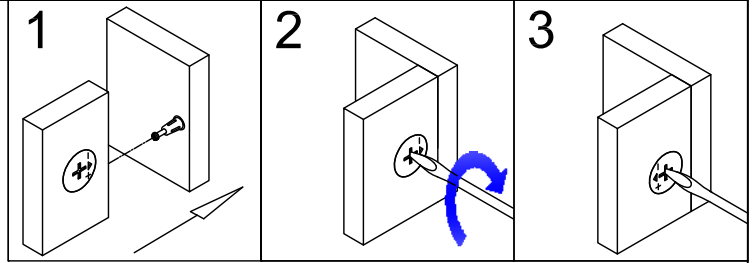

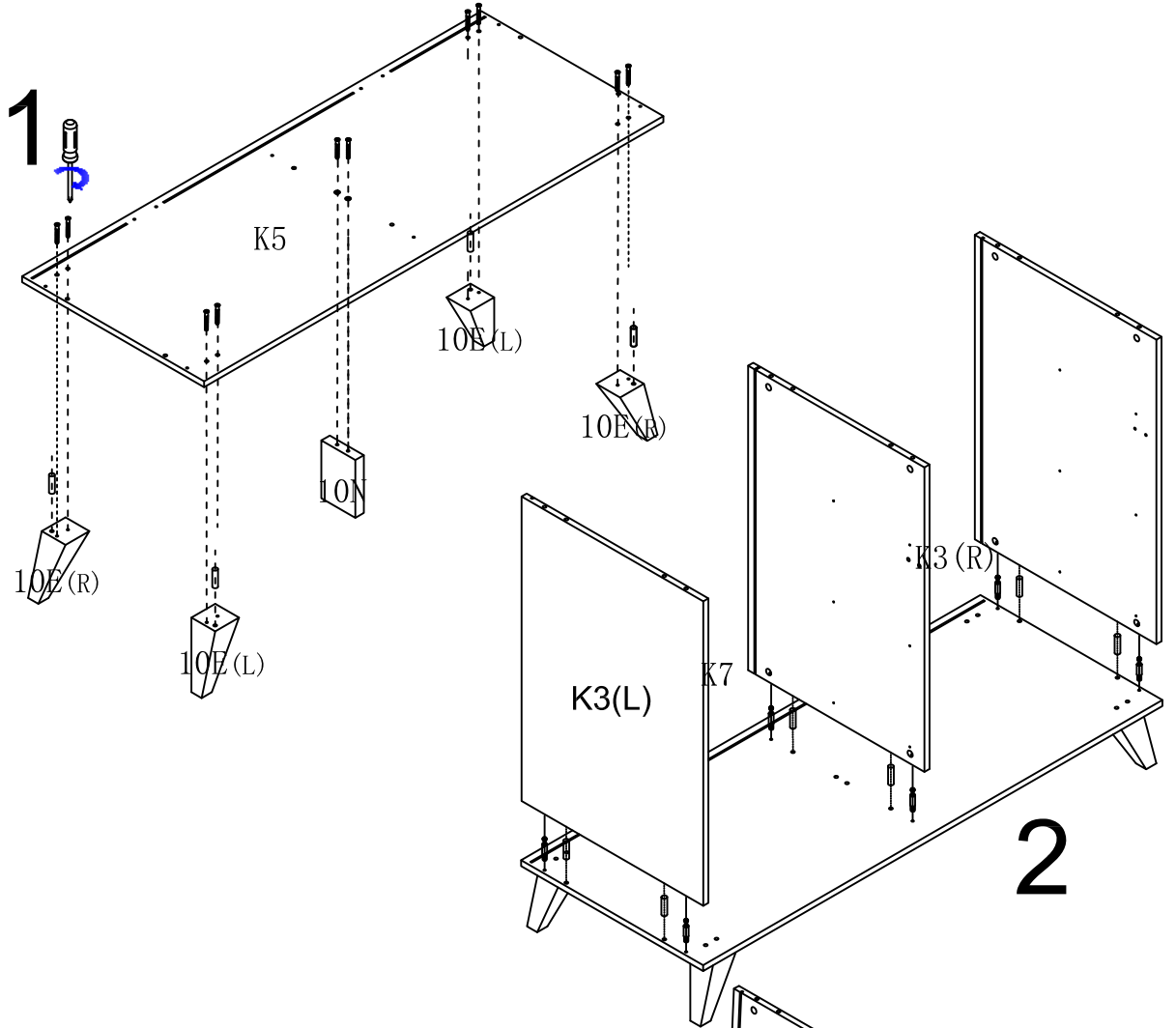

10E (LX2)
10E (RX2)
10N
K5

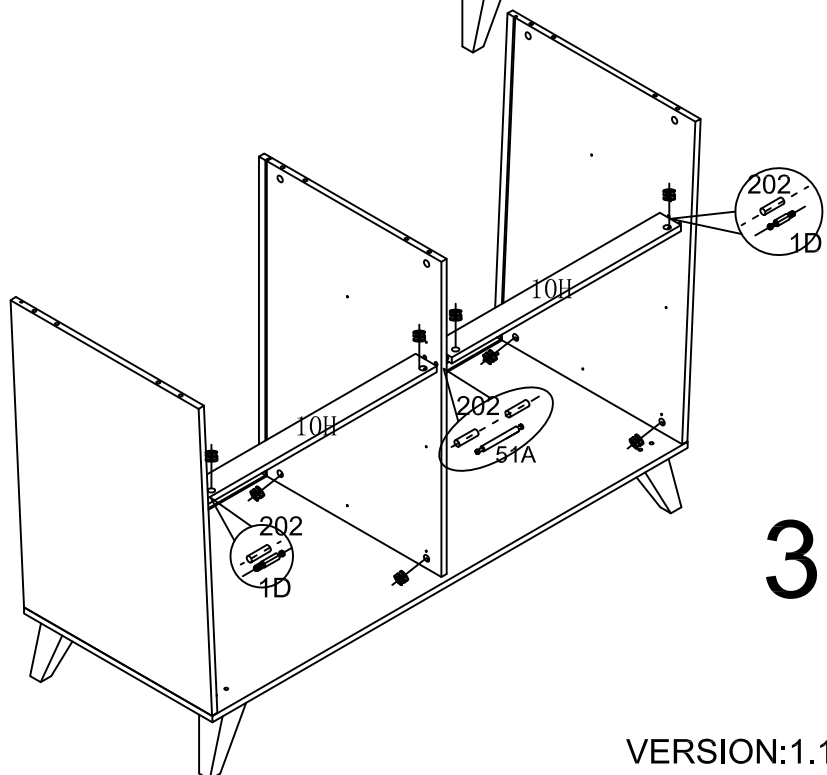

K7
10H (x2)
K3(L)
K3(R)



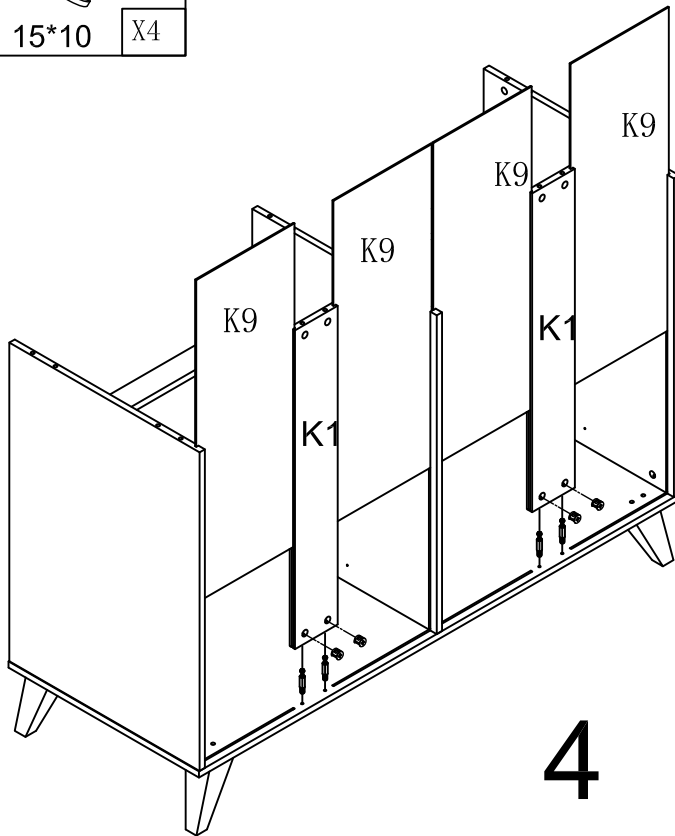

1D		203	
35mm	X4	15*10	X4

K1 (x2)
K9 (x4)





4

1D		203		202	
35mm	X10	15*10	x10	Ø8*30	X6

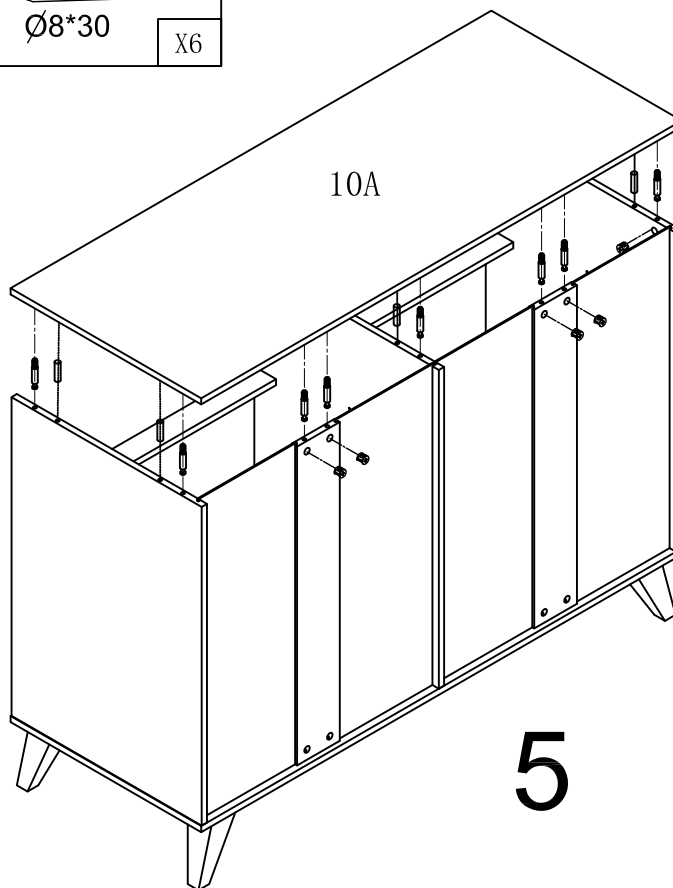
10A





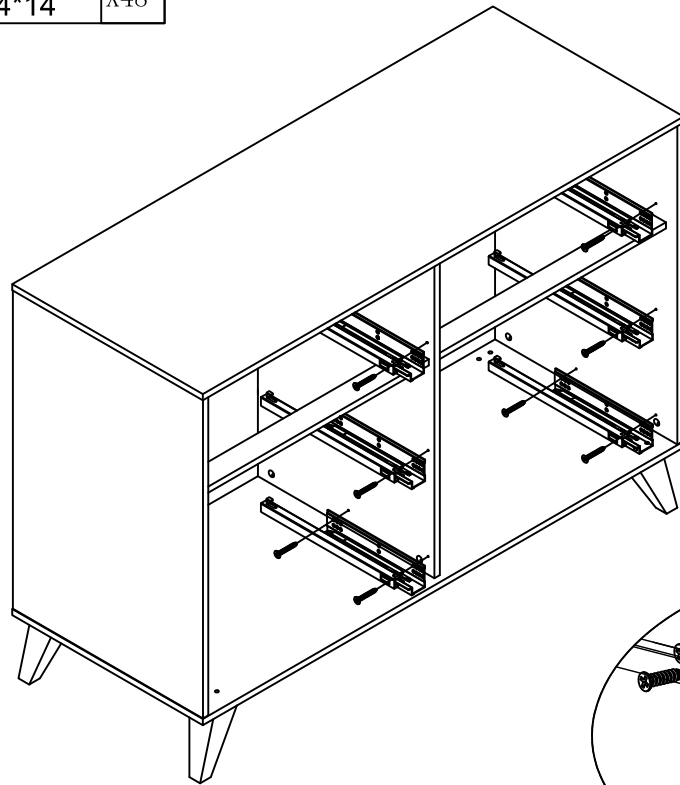

5

23I  400mm	X6	7C  ø3.4*14	X48
---	----	--	-----

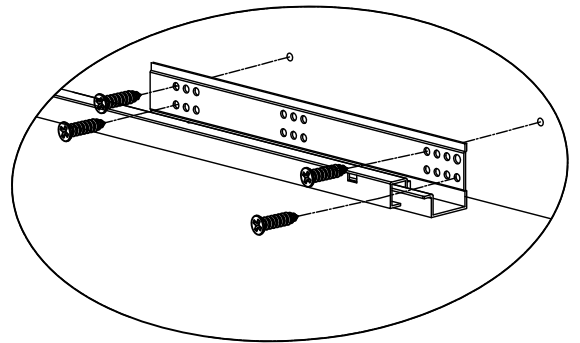

6

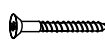
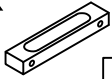

16B  M4*25	X12	1D  35mm	X36	203  15*10	X36	11  4*40	X36	47X  120mm	X6
---	-----	---	-----	---	-----	---	-----	---	----

- 10F (AX6)
- 10F (LX6)
- 10F (RX6)
- 10F (OX6)
- 10G (X6)
- 10M (X6)

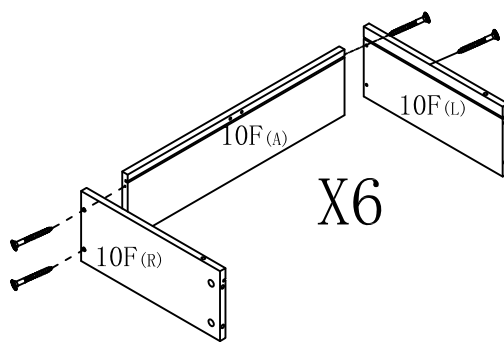

X6

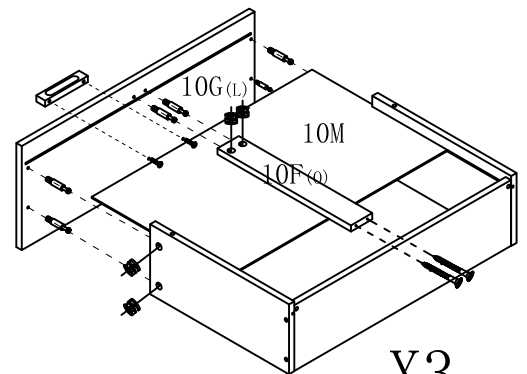

X3

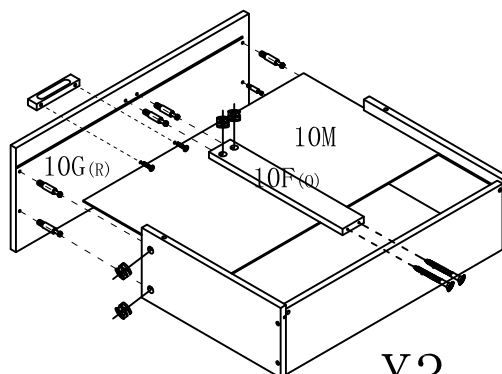

X3

7

8

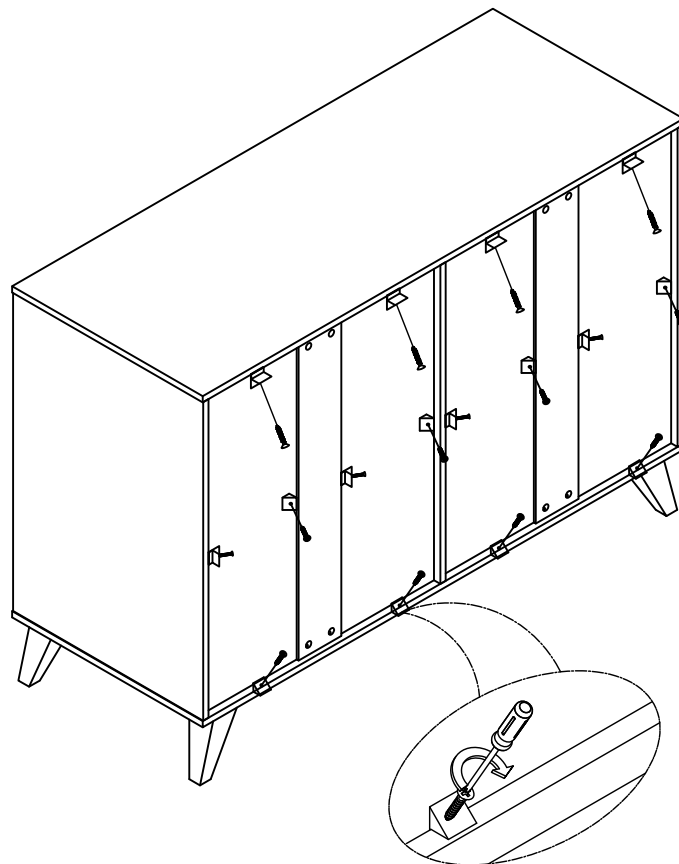
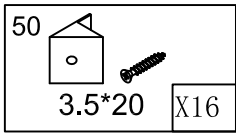
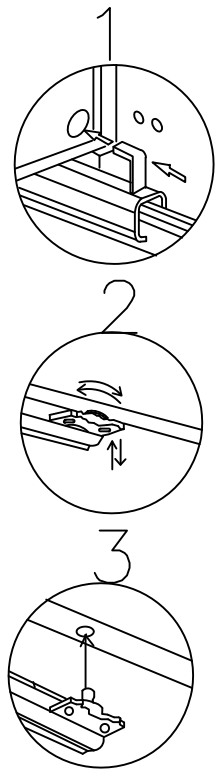
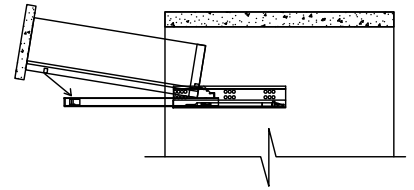
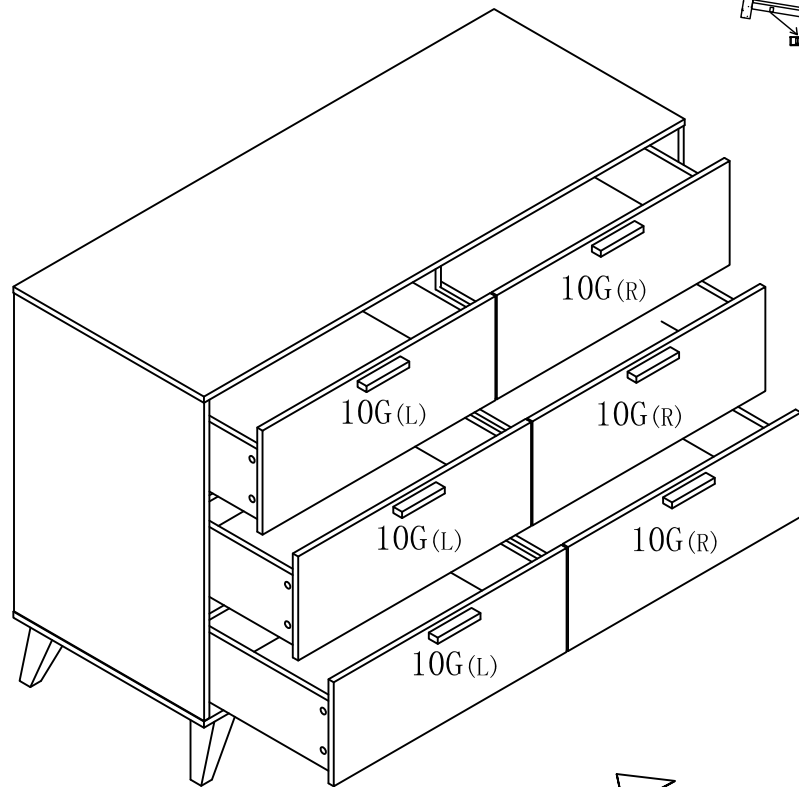

9

Veiligheidsbanden / Safety belts / Sicherheitsbande / Cordons de sûreté / Cintas de seguridad.

NL

Dit product is uitvoerig getest op sterkte, stevigheid en stabiliteit. Zorg er desondanks voor dat u er waakzaam op bent dat uw kind niet gaat klimmen en klauteren op of gaat hangen aan het meubel. In het bijzonder bij geopende lades en deuren kan dit tot gevaarlijke omstandigheden leiden. Om de veiligheid van uw kind zoveel mogelijk te kunnen garanderen dient u de bijgeleverde veiligheidsbanden volgens de handleiding te monteren.

EN

The stability and strength of this product have been tested extensively. In spite of this take good care of your child's behaviour; the child should not be climbing into or hanging on the product. This could be dangerous, especially when the drawers and doors are opened. To guarantee the safety of your child as much as possible you have to mount the included safety belts according to assembling instructions.

DE

Die Stärke und Stabilität dieses Produktes ist umfassend getestet. Beobachten Sie daß Ihr Kind nicht klettert auf oder hängt an das Möbel. Diese Situation kann gefährlich sein wenn zum Beispiel die Schubladen oder Türe geöffnet sind. Um die Sicherheit Ihres Kindes so viel wie möglich zu garantieren, verwenden Sie die Sicherheitsbande wie beschrieben im Montageanleitung.

F

Ce produit a été testé sur solidité et stabilité. Veuillez faire attention que l'enfant ne se monte pas sur le meuble, particulièrement dans le cas que les tiroirs et les portes sont ouvertes. Pour garantir la sûreté de votre enfant, veuillez monter les cordons de sûreté selon manuel.

1 ▷

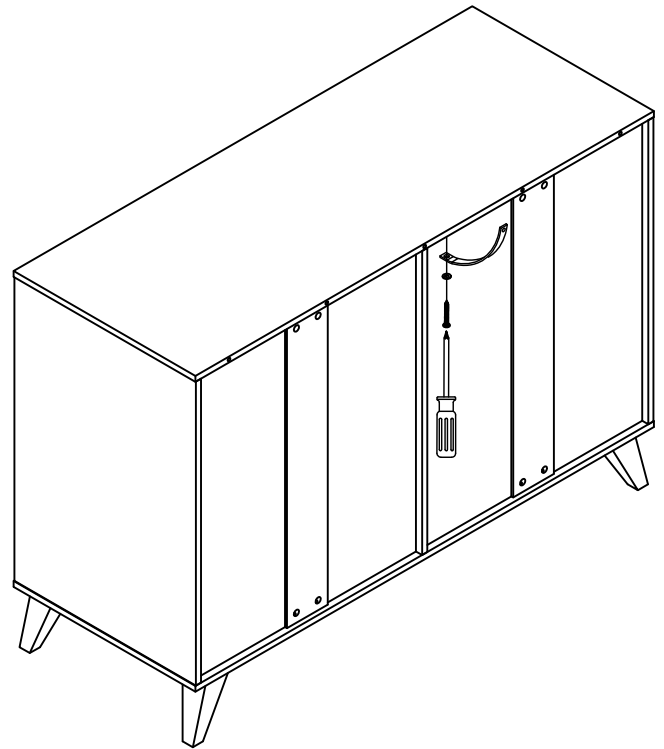
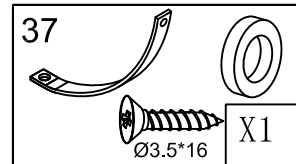

2 ▷

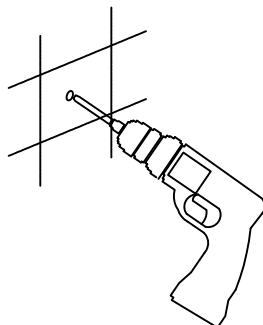

3 ▷

